

***INVERSE PROBLEMS  
TUTORIAL***

**H. T. BANKS and MARIE DAVIDIAN  
N. C. STATE UNIVERSITY  
MA/ST 810, Fall, 2009**

Concepts for inverse problems/parameter estimation problems illustrated by *examples*—Involves both *deterministic* and *probabilistic/stochastic/statistical* analysis

Includes:

- *Identifiability*
- *Ill-posedness*
- *Stability*
- *Regularization*
- *Approximation*
- *Reduced order modeling {Proper Orthogonal Decomposition(POD)/Principal Component Analysis(PCA)}*

# ***SOME GENERAL REFERENCES:***

## **JOURNALS:**

***Inverse Problems***, Institute of Physics Pub. ,(18 Vol thru 2002)

***J. Inverse and Ill-Posed Problems***, VSP, (9 Vol thru 2001)

***SIAM (J.Control and J.Appl.Math)***

## **BOOKS:**

**1. G.Anger**, *Inverse Problems in Differential Equations*, Plenum ,N.Y.,1990.

**2. H.T.Banks and K.Kunisch**, *Estimation Techniques for Distributed Parameter Systems*, Birkhauser,Boston,1989.

**3. H.T.Banks,M.W.Buksas,and T.Lin**, *Electromagnetic Material Interrogation Using Conductive Interfaces and Acoustic Wavefronts*, SIAM FR 21,Philadelphia,2002.

**4. J. Baumeister**, *Stable Solutions of Inverse Problems*, Vieweg,Braunschweig, 1987.

**5. J.V.Beck,B.Blackwell and C.St.Clair**, *Inverse Heat Conduction: Ill-posed Problems*, Wiley, N.Y.,1985.

6. **H.W.Engl and C.W.Groetsch(eds.)**, *Inverse and Ill-posed Problems*, Academic,Orlando,1987.
7. **C.W.Groetsch**, *Inverse Problems in the Mathematical Sciences*, **Vieweg**, Braunschweig,1993.
8. **C.W.Groetsch**, *The Theory of Tikhonov Regularization for Fredholm Equations of the First Kind*, **Pitman,London,1984**.
9. **B.Hoffman**, *Regularization for Applied Inverse and Ill-posed Problems*, **Teubner,Leipzig,1986**.
10. **A.N.Tikhonov and V.Y.Arsenin**, *Solutions of Ill-posed Problems*, **Winston and Sons,Washington,1977**.
11. **C.R.Vogel**, *Computational Methods for Inverse Problems*, **SIAM FR23**, Philadelphia,2002

## ***FORWARD PROBLEM***

***vs.***

## ***INVERSE PROBLEM***

Parameter dependent dynamical system:

$$\frac{dz}{dt} = g(t, z, \theta), \quad z(t_0) = z_0, \quad g \text{ known}, \quad \theta \in \Theta$$

$z(t) \in R^K$ , i.e.,  $z(t)$  is a vector

*Forward* : Given  $\theta, z_0$ , find  $z(t)$  for  $t \geq t_0$

*Inverse* : Given  $z(t)$  for  $t \geq t_0$ , find  $\theta \in \Theta$

# Mass-spring-dashpot system

$$m \frac{d^2 x}{dt^2} + c \frac{dx}{dt} + kx = F$$

$$x(0) = x_0 \quad \frac{dx}{dt}(0) = v_0$$

$x =$  equilibrium displacement  
of mass  $m$

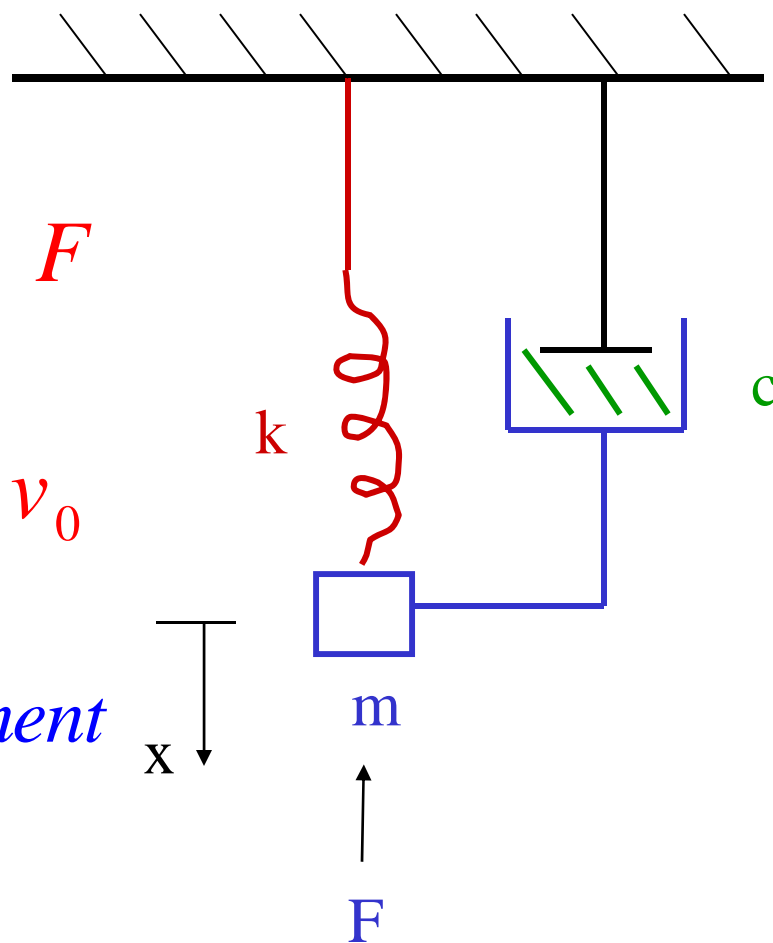

*Forward: Given  $m, c, k, F, x_0, v_0$ , find  $x(t)$  for  $t > t_0$*

*Inverse: Given  $x(t)$  for  $t \geq t_0$ ,  $v_0$ , and  $F$ , find  $m, c$ , and  $k$*

# Electronic Polarization—electronic cloud displacement

$\ell$  = displacement of negative charge of mass  $m$  from equilibrium of electronic cloud center

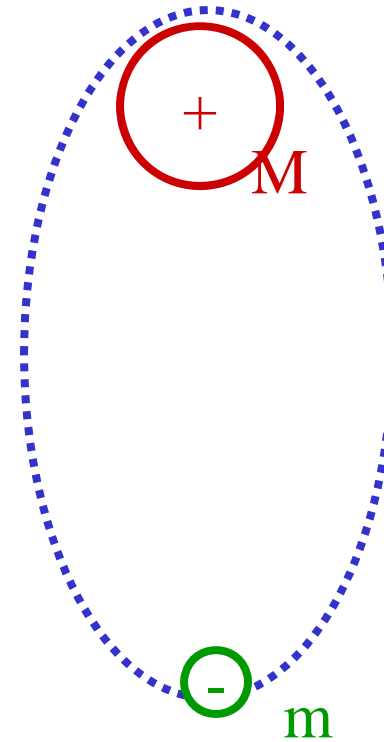
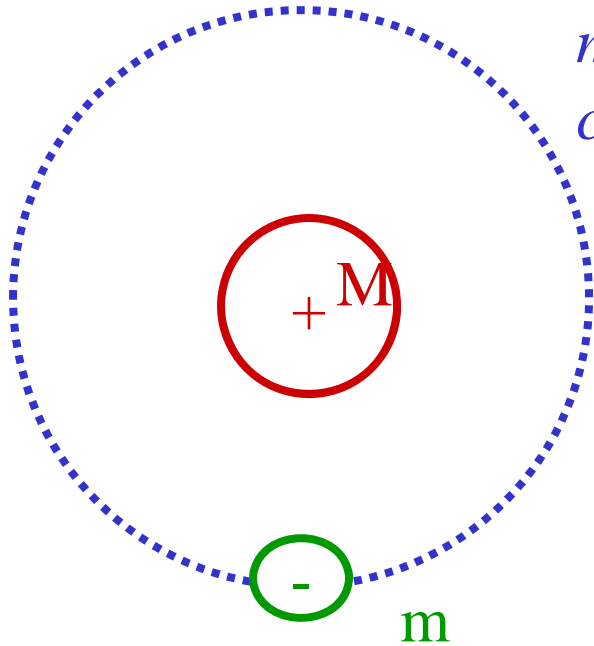

$$m \frac{d^2 \ell}{dt^2} + c \frac{d \ell}{dt} + k \ell = Q E_a(t)$$

Usually are not given observations of all of system state  $z(t)$ :

Example(mass-spring-dashpot system):

First, rewrite as first order vector system:

$$z(t) = \begin{pmatrix} x(t) \\ \frac{dx(t)}{dt} \end{pmatrix}, \quad \frac{dz(t)}{dt} = \mathcal{A}(\theta)z(t) + \mathcal{F}(t), \quad z_0 = \begin{pmatrix} x_0 \\ v_0 \end{pmatrix}$$

$$\mathcal{A}(\theta) = \begin{pmatrix} 0 & 1 \\ -\frac{k}{m} & -\frac{c}{m} \end{pmatrix} \quad \mathcal{F}(t) = \begin{pmatrix} 0 \\ \frac{F(t)}{m} \end{pmatrix} \quad \theta = \left( \frac{k}{m}, \frac{c}{m} \right)$$

*Observations :  $f(t, \theta) = \mathcal{C} z(t, \theta)$*

*Laser vibrometer :  $f(t, \theta) = v(t) = \frac{dx(t)}{dt}$*

*Observation operator :  $\mathcal{C} = (0 \quad 1)$*

*Proximity probe :  $f(t, \theta) = x(t)$*

*Observation operator :  $\mathcal{C} = (1 \quad 0)$*

*More likely, discrete (finite number)  
observations :*

$$\left\{ \tilde{y}_j \right\}_{j=1}^n \quad \text{where } \tilde{y}_j \approx f(t_j, \theta)$$

*Can formulate as least – squares fit of model to observations:*

$$J(\theta) = \sum_{j=1}^n \left| \tilde{y}_j - f(t_j, \theta) \right|^2$$

*where  $f$  is the model solution(response) or that part of the solution that we can "observe" or that we care about in design!*

## *“Model driven” vs. “data driven” inverse problems*

*Model driven:  $\tilde{y}_j = f(t_j, \theta)$*

*Data driven:  $\tilde{y}_j = f(t_j, \theta) + \varepsilon_j$ ,  $\varepsilon_j$  is error*

*(Depending on the error, may need to introduce variability into the modeling and analysis)*

*Model driven:  $\tilde{y}_j = f(t_j, \theta)$*

*i) System Design problems*

*a) design of spring / shock system (automotive, "smart" truck seats)*

*b) design of thermally conductive epoxies for use in computer motherboards*

*ii) Nondestructive Evaluation (NDE) problems*

*a) thermal interrogation of conductive structures*

*b) eddy current – based electromagnetic damage detection*

# Design of spring / shock system

(automotive, "smart" truck seats)

$$m \frac{d^2 x}{dt^2} + c \frac{dx}{dt} + kx = F$$

$$x(0) = x_0 \quad \frac{dx}{dt}(0) = v_0$$

## Mass-spring-dashpot system

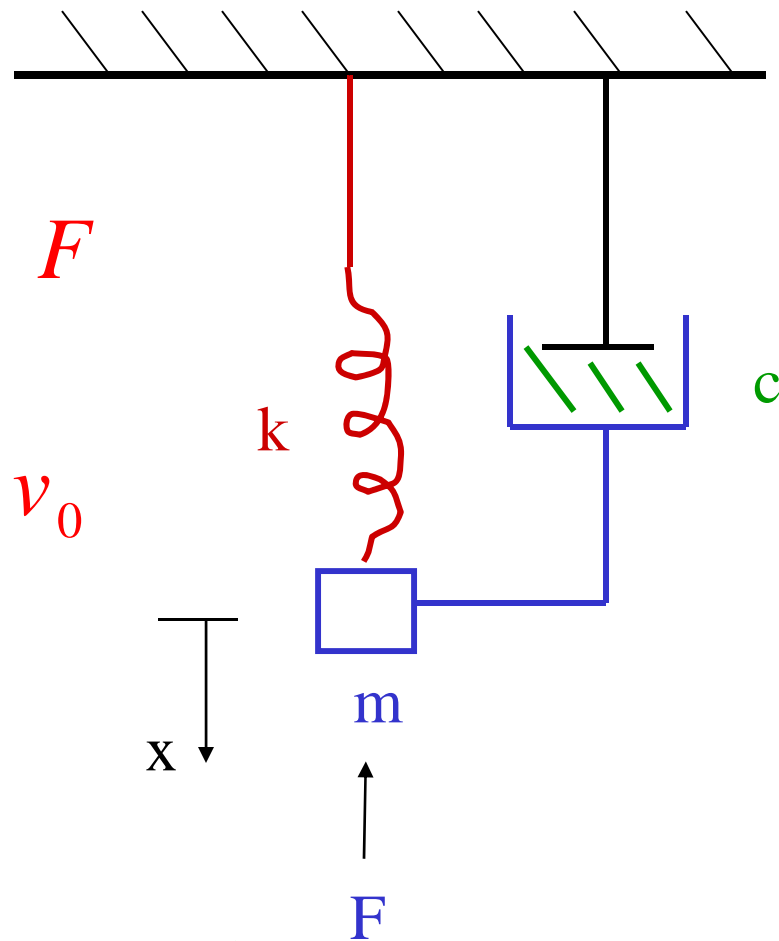

*Choose  $\theta = (k, c)$  to provide a given response  $x(t)$  for a "load"  $m$  and perturbation  $F(t)$*

# DESIGN OF THERMALLY CONDUCTIVE COMPOSITE ADHESIVES

## GOALS

Design and analysis of thermally conductive composite adhesives (epoxies and gels filled with highly conductive particles such as aluminum, diamond dust, and carbon)

## POTENTIAL AND SIGNIFICANCE

Development of enhanced thermally conductive adhesives for microelectronic devices, automotive and aeronautical components

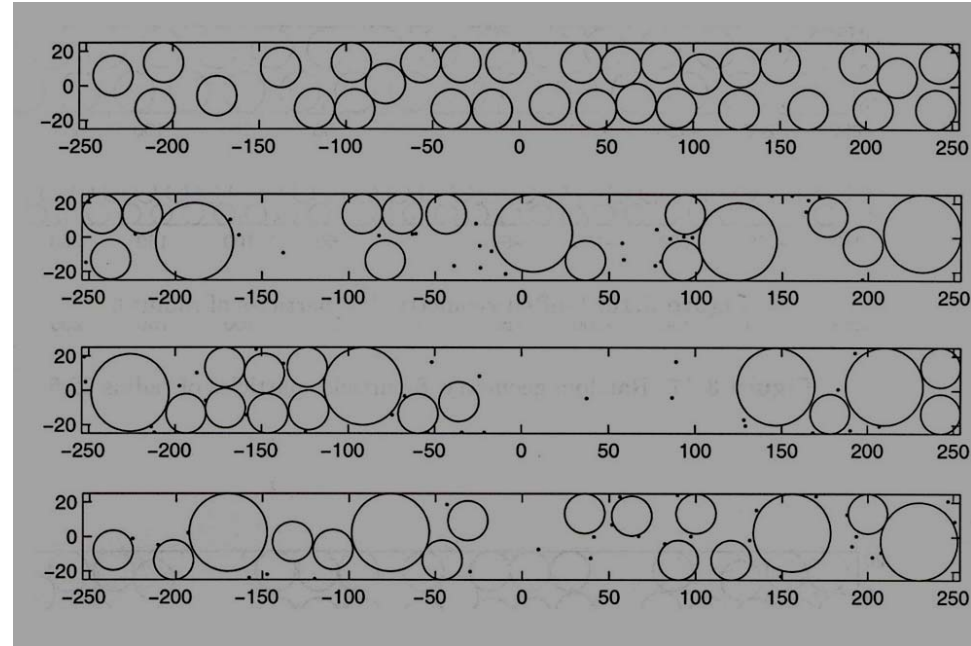

*Determine  $\rho, c_p$ , and  $k$  (all spatially varying) in*

$$\rho(\vec{x})c_p(\vec{x})\frac{\partial u(t, \vec{x})}{\partial t} = \nabla(k(\vec{x})\nabla u(t, \vec{x}))$$

*for a desired temperature  $u$  or flux  $\frac{\partial u}{\partial n} = \nabla u \cdot \vec{n}$*

*on the boundary*

## ***References:***

- 1) H.T.Banks and K.L.Bihari, Modeling and estimating uncertainty in parameter estimation, CRSC-TR99-40, NCSU, Dec.,1999; Inverse Problems 17(2001),1-17.**
- 2) K.L.Bihari, *Analysis of Thermal Conductivity in Composite Adhesives*, Ph.D. Thesis, NCSU, August, 2001.**
- 3) H.T.Banks and K.L.Bihari, Analysis of thermal conductivity in composite adhesives, CRSC-TR01-20, NCSU, August, 2001; Numerical Functional Analysis and Optimization, Dec.,2002, to appear.**

# DAMAGE DETECTION USING EDDY CURRENT TECHNIQUES

## GOALS

Develop fast on-line computational methods for use with highly sensitive magnetic flux sensors in detection of subsurface damages

## POTENTIAL AND SIGNIFICANCE

Development of portable, real time scanning devices for damage detection in conductive materials. Potential for fast scanners for nondestructive evaluation in aging aircraft, spacecraft and other structures

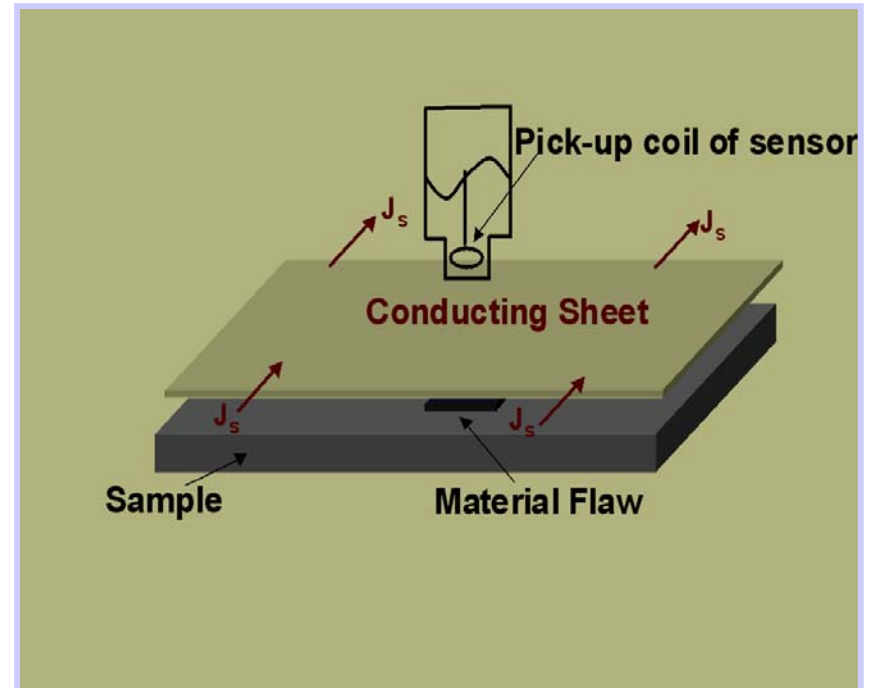

Using measurements of the magnetic vector potential  $\mathbf{A}$ ,  
determine any voids in the material (characterized by  $\sigma = 0$ ) where

$$\nabla \times \left( \frac{1}{\mu(x, y)} \nabla \times \mathbf{A}(x, y) \right) = (\sigma(x, y) + i\omega\epsilon(x, y))(-i\omega\mathbf{A}(x, y) - \nabla\phi) \quad \text{for } (x, y) \in \Omega,$$

$$I_{cs} = \int_{cs} (\sigma(x, y) + i\omega\epsilon(x, y))(-i\omega\mathbf{A}(x, y) - \nabla\phi) \cdot \mathbf{n} da \quad \text{for } (x, y) \in cs$$

## References:

- 1) H.T.Banks,M.L.Joyner,B.Wincheski,and W.P.Winfree, Evaluation of material integrity using reduced order computational methodology, CRSC-TR99-30, NCSU, August, 1999.
- 2) H.T.Banks,M.L.Joyner,B.Wincheski,and W.P.Winfree, Nondestructive evaluation using a reduced-order computational methodology, ICASE Tech Rep 2000-10, NASA LaRC, March 2000; Inverse Problems 16(2000),929-945.
- 3) H.T.Banks,M.L.Joyner,B.Wincheski,and W.P.Winfree, A reduced order computational methodology for damage detection in structures, in Nondestructive Evaluation of Ageing Aircraft, Airports and Aerospace Hardware (A.K.Mal,ed.) SPIE 3994(2000),10-17.
- 4) H.T.Banks,M.L.Joyner,B.Wincheski,and W.P.Winfree, Electromagnetic interrogation techniques for damage detection,CRSC-TR01-15,NCSU, June,2001; Proceedings ENDEO (Kobe, Japan, May,2001), to appear.
- 5) H.T.Banks,M.L.Joyner,B.Wincheski,and W.P.Winfree, Real time computational algorithms for eddy current based damage detection, CRSC-TR01-16,NCSU,June,2001; Inverse Problems, to appear.
- 6) M.L.Joyner, *An Application of a Reduced Order Computational Methodolgy for Eddy Current Based Nondestructive Evaluation Techniques*, Ph.D. Thesis, NCSU, June, 2001.

*Data driven:  $\tilde{y}_j = f(t_j, \theta) + \varepsilon_j$ ,  $\varepsilon_j$  is error*

**Many (most!) of examples lead to the introduction of *variability* into both the modeling and the analysis!!**

- i) Physiologically Based Pharmacokinetic (PBPK) modeling in toxicokinetics
- ii) Modeling of HIV pathogenesis

## PBPK Models for TCE in Fat Cells

Millions of cells with  
varying size, residence  
time, vasculature,  
geometry:

“Axial-dispersion” type  
adipose tissue compartments  
to embody uncertain  
physiological heterogeneities  
in single organism (rat) =  
*intra-individual variability*

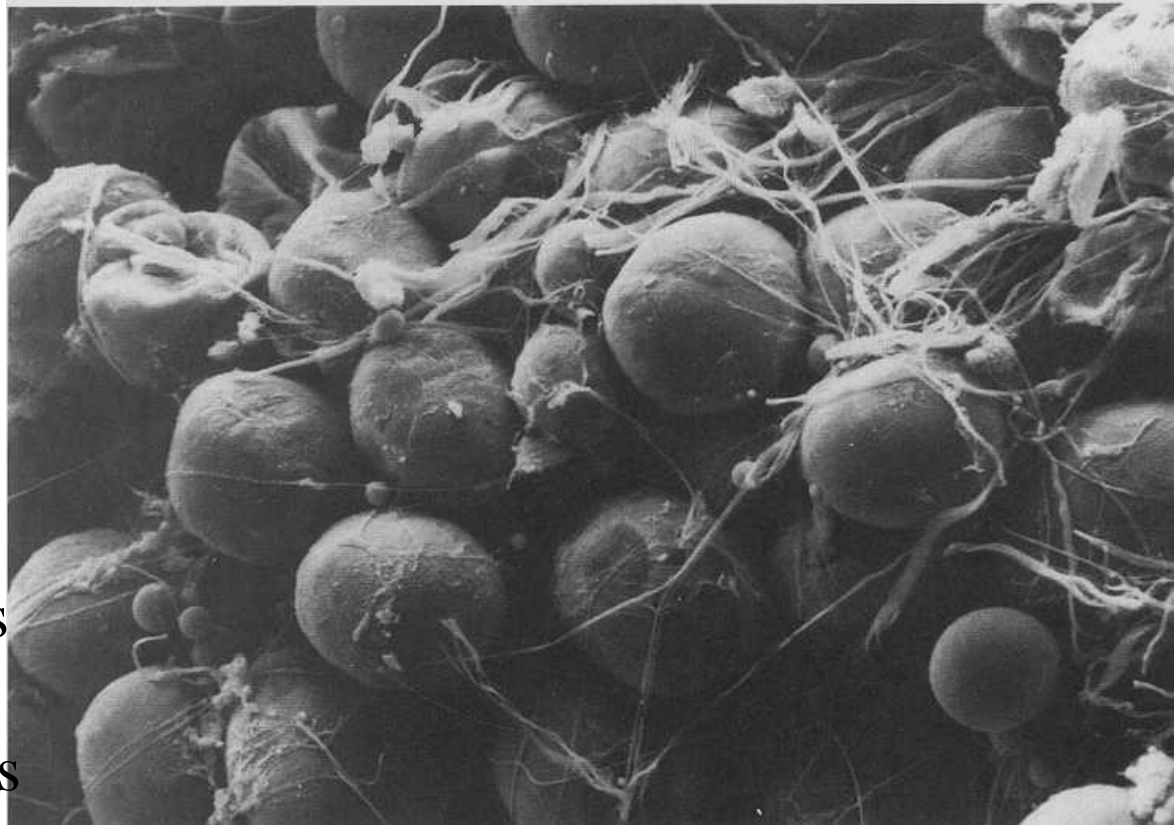

*Inter-individual variability* treated with parameters (including dispersion parameters) as *random variables* –estimate *distributions* from *aggregate data* (multiple rat data) which also contains uncertainty (noise)

# Whole-body system of equations

$$V_v \frac{dC_v(t)}{dt} = Q_f C_B(t, \pi - \varepsilon_2) + \frac{Q_{br}}{P_{br}} C_{br}(t) + \frac{Q_k}{P_k} C_k(t) + \frac{Q_l}{P_l} C_l(t) + \frac{Q_m}{P_m} C_m(t) + \frac{Q_t}{P_t} C_t(t) - Q_c C_v(t)$$

$$C_a(t) = (Q_c C_v(t) + Q_p C_c(t)) / (Q_c + Q_p / P_b)$$

$$V_{br} \frac{dC_{br}(t)}{dt} = Q_{br} (C_a(t) - C_{br}(t) / P_{br})$$

$$V_B \frac{\partial C_B}{\partial \phi} = \frac{V_B}{r_2 \sin \phi} \frac{\partial}{\partial \phi} \left[ \sin \phi \left( \frac{D_B}{r_2} \frac{\partial C_B}{\partial \phi} - v C_B \right) \right] + \lambda_I \mu_{BI} (f_I C_I(\theta_0) - f_B C_B) + \lambda_A \mu_{BA} (f_A C_A(\theta_0) - f_B C_B)$$

$$V_I \frac{\partial C_I}{\partial t} = \frac{V_I D_I}{r_1^2} \left[ \frac{1}{\sin^2 \phi} \frac{\partial^2 C_I}{\partial \theta^2} + \frac{1}{\sin \phi} \frac{\partial}{\partial \phi} \left( \sin \phi \frac{\partial C_I}{\partial \phi} \right) \right] + \delta_{\theta_0}(\theta) \chi_B(\phi) \lambda_I \mu_{BI} (f_B C_B - f_I C_I) + \mu_{IA} (f_A C_A - f_I C_I)$$

$$V_A \frac{\partial C_A}{\partial t} = \frac{V_A D_A}{r_0^2} \left[ \frac{1}{\sin^2 \phi} \frac{\partial^2 C_A}{\partial \theta^2} + \frac{1}{\sin \phi} \frac{\partial}{\partial \phi} \left( \sin \phi \frac{\partial C_A}{\partial \phi} \right) \right] + \delta_{\theta_0}(\theta) \chi_B(\phi) \lambda_A \mu_{BA} (f_B C_B - f_A C_A) + \mu_{IA} (f_I C_I - f_A C_A)$$

$$V_k \frac{dC_k(t)}{dt} = Q_k (C_a(t) - C_k(t) / P_k)$$

$$V_l \frac{dC_l(t)}{dt} = Q_l \left( C_a(t) - \frac{C_l(t)}{P_l} \right) - \left( v_{\max} \frac{C_l(t)}{P_l} \right) / \left( k_M + \frac{C_l(t)}{P_l} \right)$$

$$V_m \frac{dC_m(t)}{dt} = Q_m (C_a(t) - C_m(t) / P_m)$$

$$V_t \frac{dC_t(t)}{dt} = Q_t (C_a(t) - C_t(t) / P_t)$$

Plus boundary conditions  
and initial conditions

## References:

- 1) **R.A.Albanese,H.T.Banks,M.V.Evans,and L.K.Potter, PBPK models for the transport of trichloroethylene in adipose tissue,CRSC-TR01-03,NCSU,Jan.2001; Bull. Math Biology 64(2002), 97-131**
- 2) **H.T.Banks and L.K.Potter,Well-posedness results for a class of toxicokinetic models,CRSR-TR01-18,NCSU,July,2001; Discrete and Continuous Dynamical Systems,submitted**
- 3) **L.K.Potter,*Physiologically based pharmacokinetic models for the systemic transport of Trichloroethylene*, Ph.D. Thesis,NCSU, August, 2001**
- 4) **H.T.Banks and L.K. Potter, Model predictions and comparisons for three Toxicokinetic models for the systemic transport of TCE,CRSC-TR01-23,NCSU, August,2001; Mathematical and Computer Modeling 35(2002), 1007-1032**
- 5) **H.T.Banks and L.K.Potter, Probabilistic methods for addressing uncertainty and variability in biological models: Application to a toxicokinetic model, CRSC-TR02-27,NCSU,Sept.2002; Math. Biosciences, submitted.**

# MODELING OF HIV PATHOGENESIS

## GOALS

DEVELOPMENT OF DYNAMIC MODELS INVOLVING INTRA- AND INTER-INDIVIDUAL VARIABILITY TO AID IN UNDERSTANDING OF FUNDAMENTAL MECHANISMS OF INFECTION AND SPREAD OF DISEASE-AGGREGATE DATA ACROSS POPULATIONS

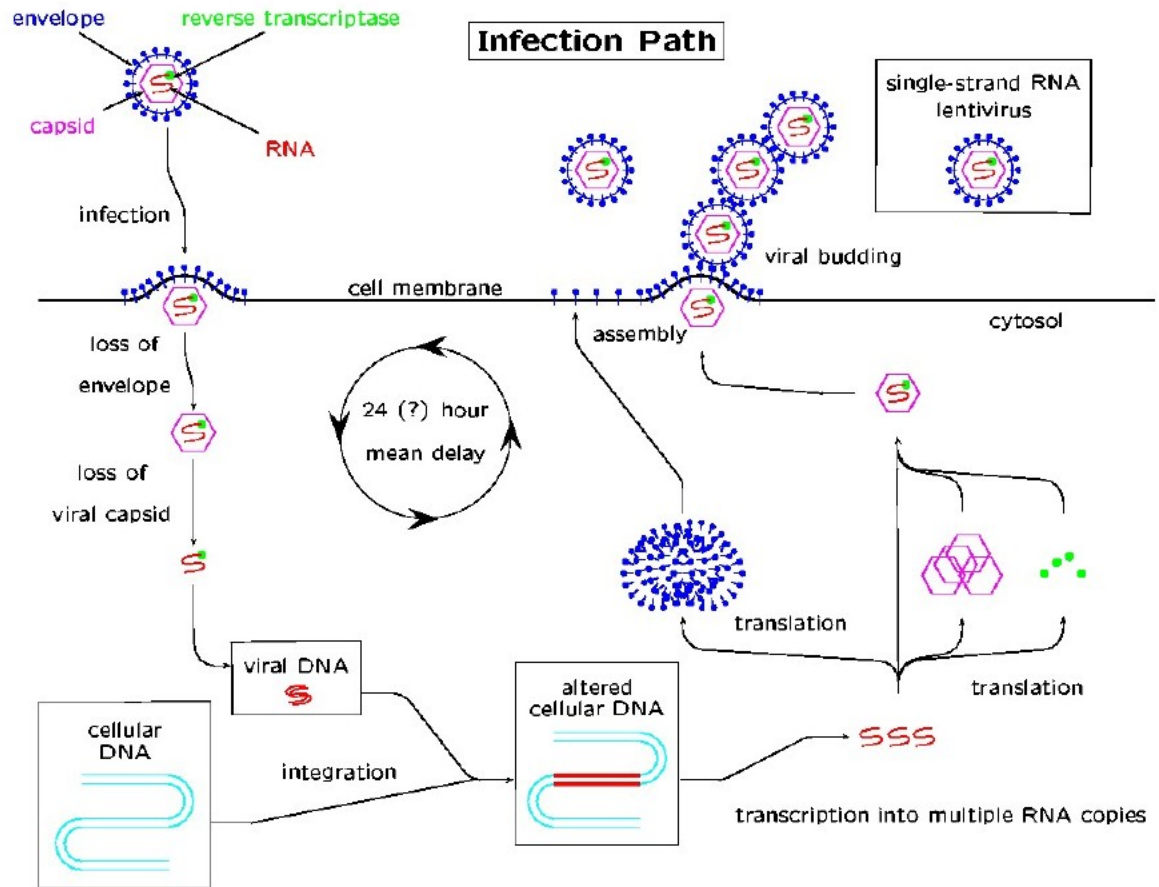

POTENTIAL AND SIGNIFICANCE  
POPULATION LEVEL ESTIMATION OF  
SPREAD RATES AND EFFICACY IN  
TREATMENT PROGRAMS FOR  
EXPOSURE

Involves systems of equations of the form (generally nonlinear)

$$\frac{dV}{dt} = -cV(t) + n_a A(t - \tau) + n_c C(t) - n_{vt} V(t)T(t)$$

where  $\tau$  is a production delay (distributed across the population of cells). That is, one should write

$$\frac{dV}{dt} = -cV(t) + n_a \int_0^{\infty} A(t - \tau)k(\tau)d\tau + n_c C(t) - n_{vt} V(t)T(t)$$

where **k** is a probability density to be estimated from aggregate data.

Even if **k** is given, these systems are nontrivial to simulate—require development of fundamental techniques.

## HIV Model:

$$\dot{V}(t) = -cV(t) + n_A \int_0^r A(t-\tau) d\pi_1(\tau) + n_C C(t) - p(V, T)$$

$$\dot{A}(t) = (r_v - \delta_A - \delta X(t))A(t) - \gamma \int_0^r A(t-\tau) d\pi_2(\tau) + p(V, T)$$

$$\dot{C}(t) = (r_v - \delta_C - \delta X(t))C(t) + \gamma \int_0^r A(t-\tau) d\pi_2(\tau)$$

$$\dot{T}(t) = (r_u - \delta_u - \delta X(t))T(t) - p(V, T) + S$$

where  $C(t) = E_2 \{C(t; \tau)\} = \int_0^r C(t; \tau) d\pi_2(\tau)$  ,  $A =$  acute cells

$$V(t) = V_A(t) + V_C(t), \quad V_A(t) = E_1 \{V_A(t; \tau)\} = \int_0^r V_A(t; \tau) d\pi_1(\tau)$$

$\pi_1 \leftrightarrow$  delay from acute infection to viral production

$\pi_2 \leftrightarrow$  delay from acute infection to chronic infection

$T =$  target cells,  $X =$  total (infected+uninfected) cells

## References:

- 1) **D. Bortz, R. Guy, J. Hood, K. Kirkpatrick, V. Nguyen, and V. Shimanovich, Modeling HIV infection dynamics using delay equations, in 6<sup>th</sup> CRSC Industrial Math Modeling Workshop for Graduate Students, NCSU(July,2000), CRSC TR00-24, NCSU, Oct, 2000**
- 2) **H. T. Banks, D. M. Bortz, and S. E. Holte, Incorporation of variability into the modeling of viral delays in HIV infection dynamics, CRSC-TR01-25, Sept, 2001; Math Biosciences, submitted.**
- 3) **H.T.Banks and D.M.Bortz, A parameter sensitivity methodology in the context of HIV delay equation models, CRSC-TR02-24, August, 2002; J. Math. Biology, submitted**
- 4) **D.M.Bortz, *Modeling, Analysis, and Estimation of an In Vitro HIV Infection Using Functional Differential Equations*, Ph. D. Thesis, NCSU, August, 2002.**

The problems above are ( as are most others) notoriously *ill-posed!!* This concept is difficult to explain in the context of the problems outlined above—so we turn to some exceedingly simple examples to illustrate the ideas behind *well-posedness!* *Simplest case:*

*one observation –  $\tilde{y}$  for  $f(\theta)$  – and need to find preimage*

*$\theta^* = f^{-1}(\tilde{y})$  for a given  $\tilde{y}$*

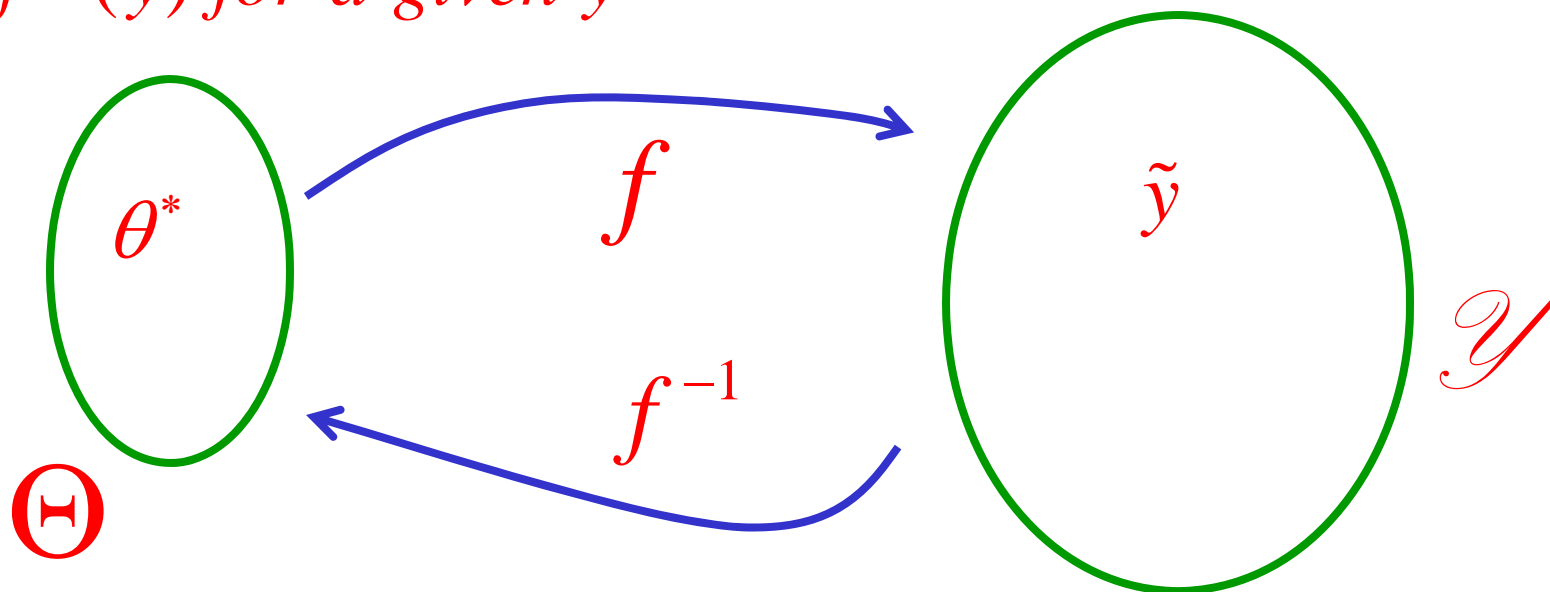

## Well-posedness:

*i. Existence*  
*i. Uniqueness* } *Identifiability*

*ii. Continuous dependence of solutions on observations*

*“stability” of inverse problem*

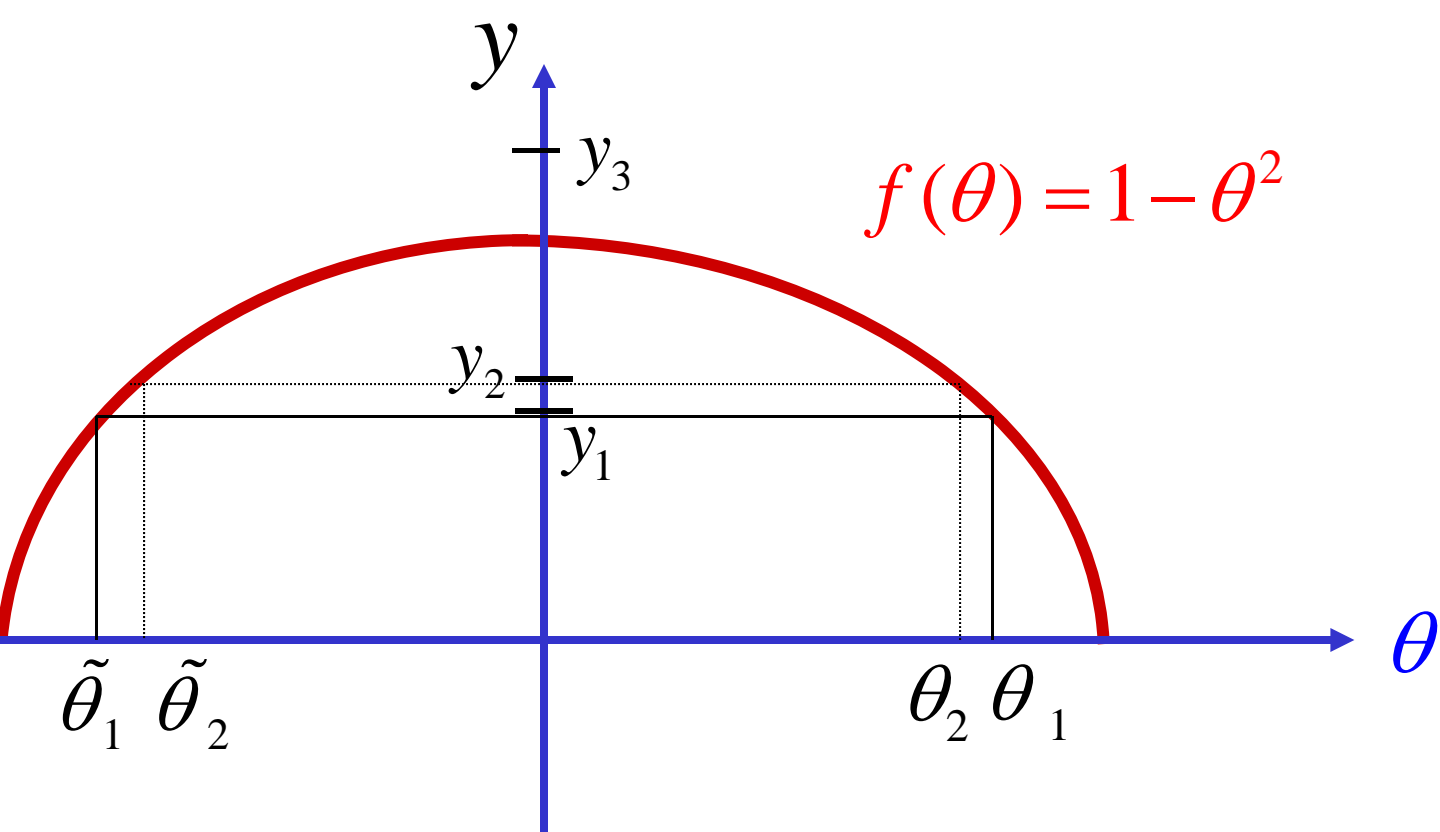

**Non-existence:** No  $\theta_3$  such that  $f(\theta_3) = y_3$

**Non-uniqueness:**  $y_j = f(\theta_j) = f(\tilde{\theta}_j) \quad j = 1, 2$

**Lack of continuity of inverse map:**

$$\begin{aligned}
 |y_1 - y_2| \text{ small} &\not\Rightarrow |f^{-1}(y_1) - f^{-1}(y_2)| \\
 &= |\theta_1 - \tilde{\theta}_2| \text{ small}
 \end{aligned}$$

## *Why is this so important???*

*Why not just apply a good numerical algorithm for a least squares (for example) fit to try to find the “best” possible solution???? (Seldom expect zero residual!!)*

*Define  $J(\theta) = |y_1 - f(\theta)|^2$  for a given  $y_1$*

*and then apply a standard iterative method to obtain a solution!!*

*Iterative methods:*

*1) Direct search (simplex, Nelder-Mead,.....)*

*2) Gradient based (Newton, steepest descent, conjugate gradient,.....)*

*e.g., Newton:  $\theta^{k+1} = \theta^k - [J'(\theta^k)]^{-1} J(\theta^k)$*

$$\theta^{k+1} = \theta^k - [J'(\theta^k)]^{-1} J(\theta^k)$$

For  $J(\theta) = |y_1 - f(\theta)|^2$ ,  $J'(\theta) = 2(y_1 - f(\theta))(-f'(\theta))$

$J'(\theta^0) = 2(-)(- -) < 0$ ,  $\Rightarrow \theta^1 > \theta^0$ , etc.

$J'(\tilde{\theta}^0) = 2(-)(- +) > 0$ ,  $\Rightarrow \tilde{\theta}^1 < \tilde{\theta}^0$ , etc.

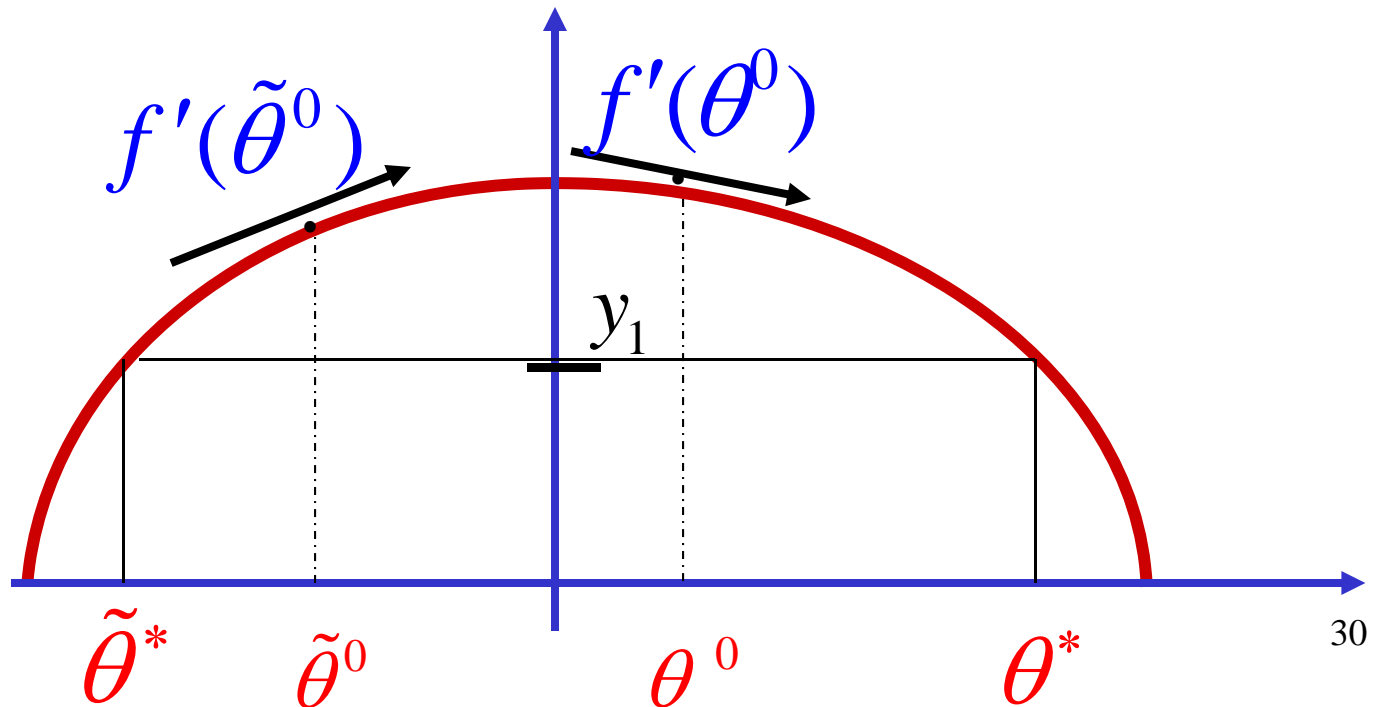

**This behavior is not the fault of steepest descent algorithms, but is a manifestation of the inherent “ill-posedness” of the problem!!**

**How to fix this is the subject of much research over the past 40 years!! Among topics are:**

- i) constrained optimization*** {
  - explicit(compact constraint sets)**
  - implicit(Lagrange multipliers)**
- ii) regularization*** {
  - a) Tikhonov regularization(1963)  
(compactification, convexification)**
  - b) regularization by discretization**

## *Tikhonov regularization*

*Idea: Problem for  $J(\theta) = |y_1 - f(\theta)|^2$  is ill-posed, so replace it by a "near-by" problem for*

$$J_\beta(\theta) = |y_1 - f(\theta)|^2 + \beta|\theta - \theta_0|^2$$

*where  $\beta$  is a regularization parameter to be "appropriately chosen" !!*

**PRO:** When done correctly, provides convexity and compactness in the problem!

**CON:** Even when done correctly, it **changes the problem** and solutions to the new problems may not be close to those of original! Moreover, it is not easy to do correctly or even to know if you have done so!!

## EXAMPLE:

$f(\theta) = 1 + \alpha \sin(\pi\theta)$ ,  $\beta$  ranging from  $\beta = 0$  to 100 thru values 0, .01, ..., 1.0, ..., 10, ..., 40, ..., 80, 100, several values of  $\alpha$ ,  $\theta_0$ , and  $y_1$

- 1)  $\alpha=1, y_1 = 1.5, \theta_0 = 0$  (tik)\*
- 2)  $\alpha=.5, y_1 = .8, \theta_0 = 0$  (tik1)
- 3)  $\alpha=.5, y_1 = 1.6$  (not in range of  $f$ ),  $\theta_0 = 0$  (tik2)\*
- 4)  $\alpha=1, y_1 = 1.5, \theta_0 = 1.0$  (tik4)
- 5)  $\alpha = 1, y_1 = 1.5, \theta_0 = 1.8$  (tik6)\*
- 6)  $\alpha = 1, y_1 = 1.5, \theta_0 = .5$  (tik7)\*
- 7)  $\alpha = 1, y_1 = 1.5, \theta_0 = -.5$  (tik8)\*

(alt / tab)

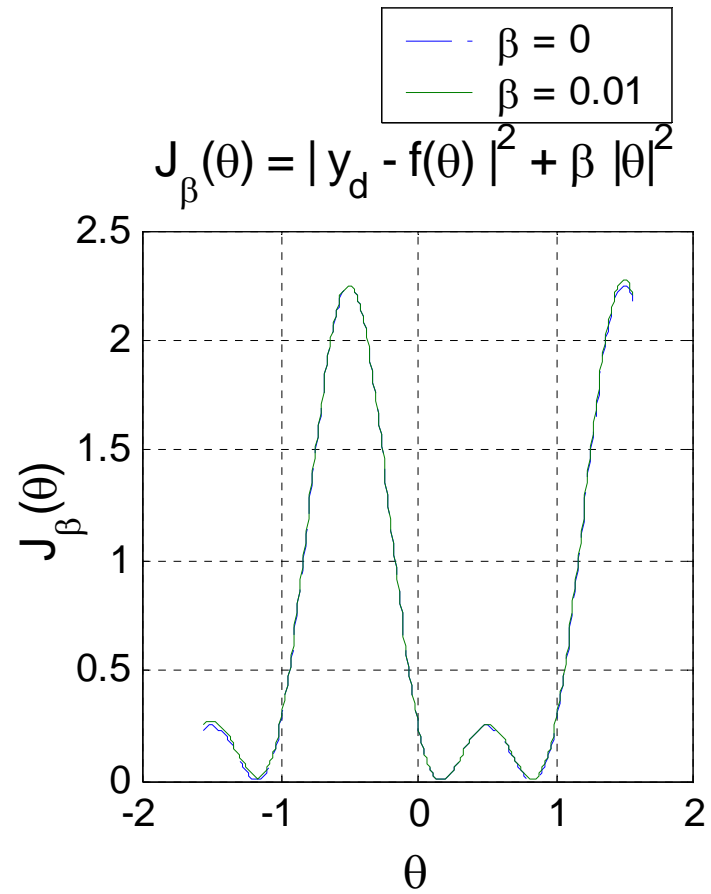
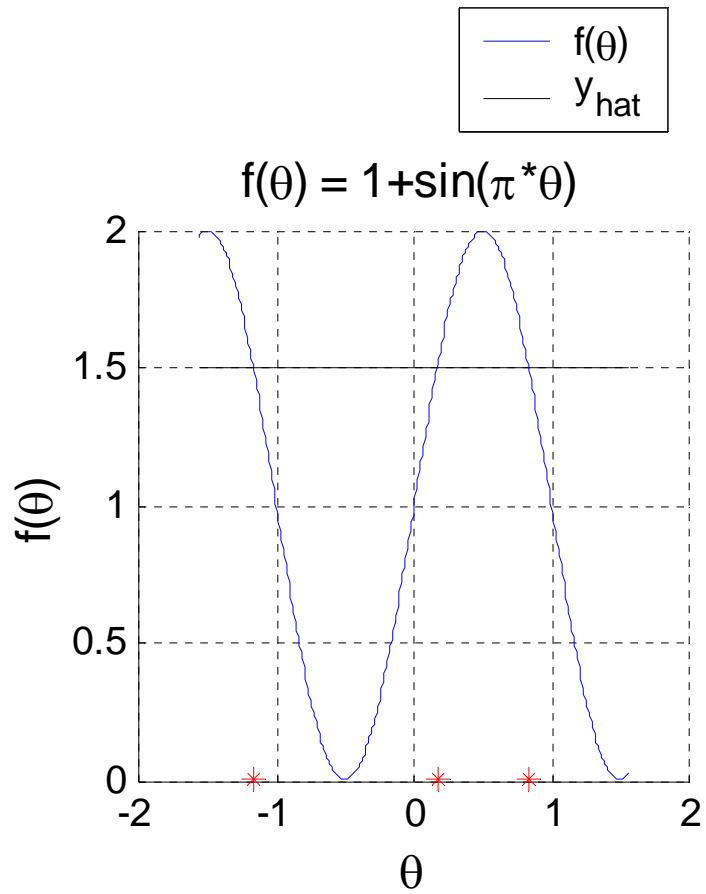

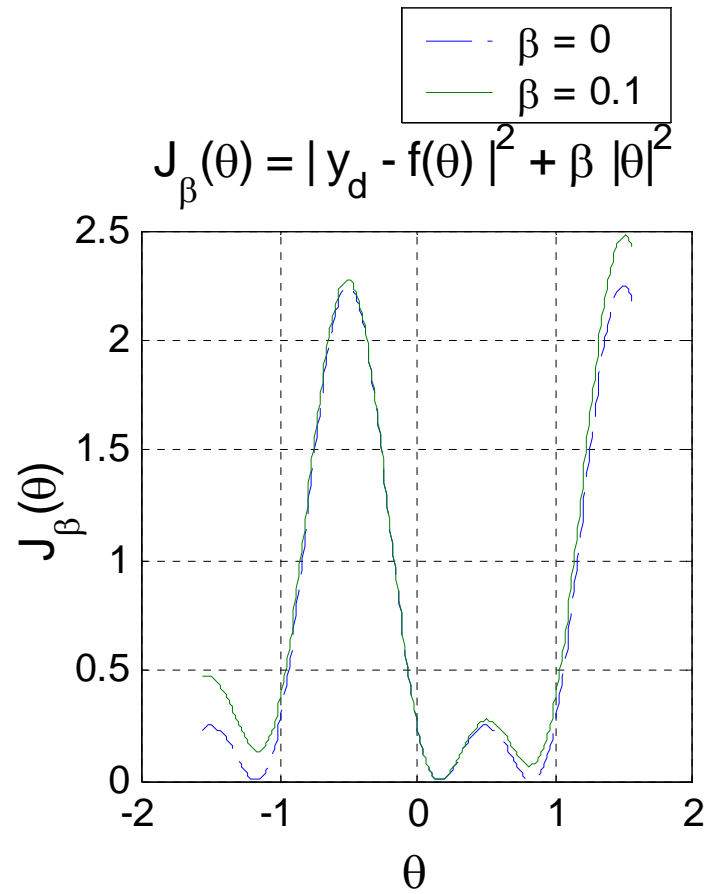
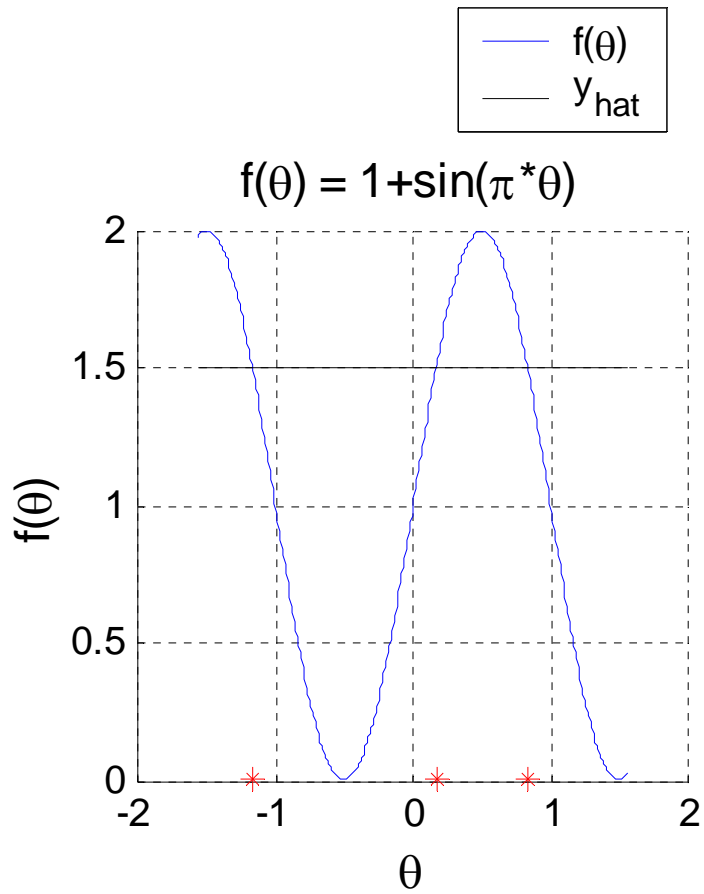

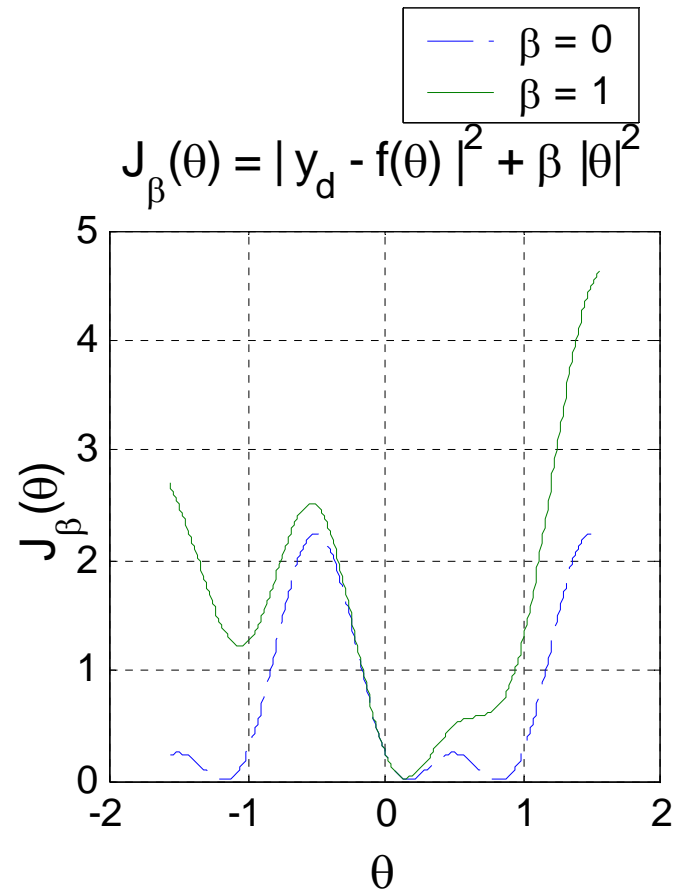
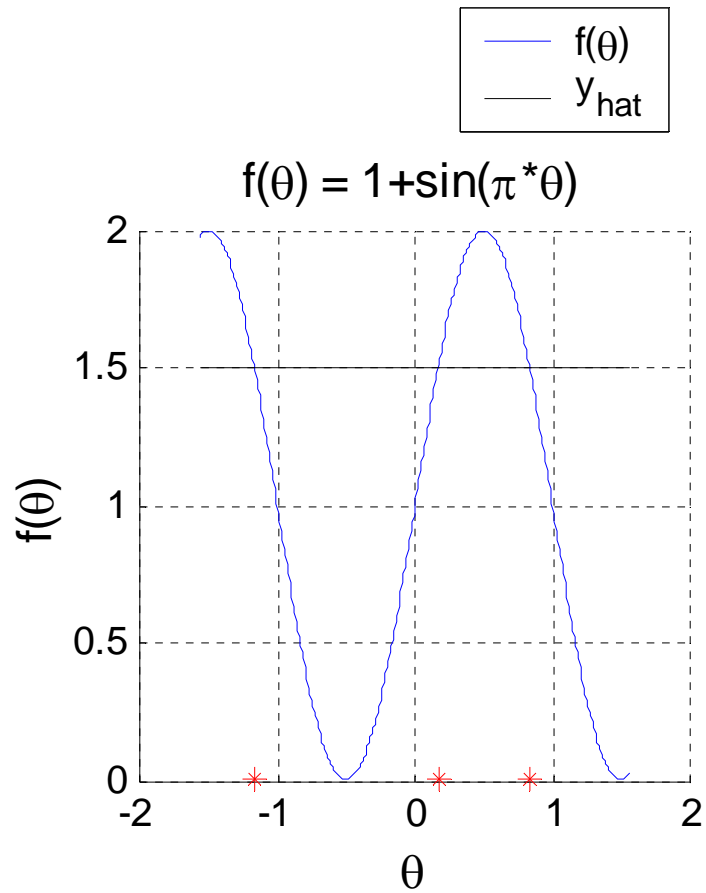

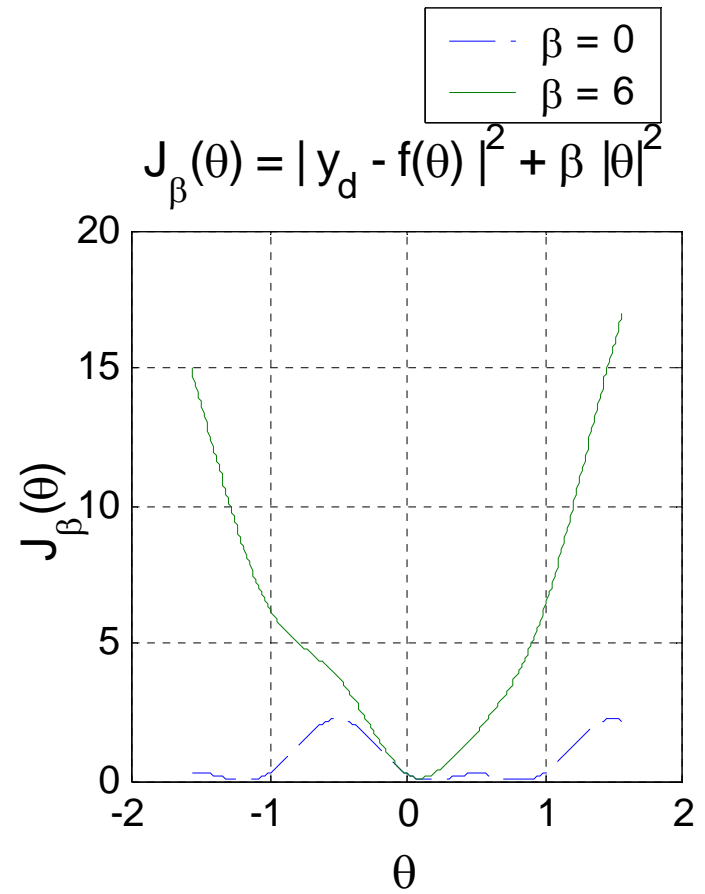
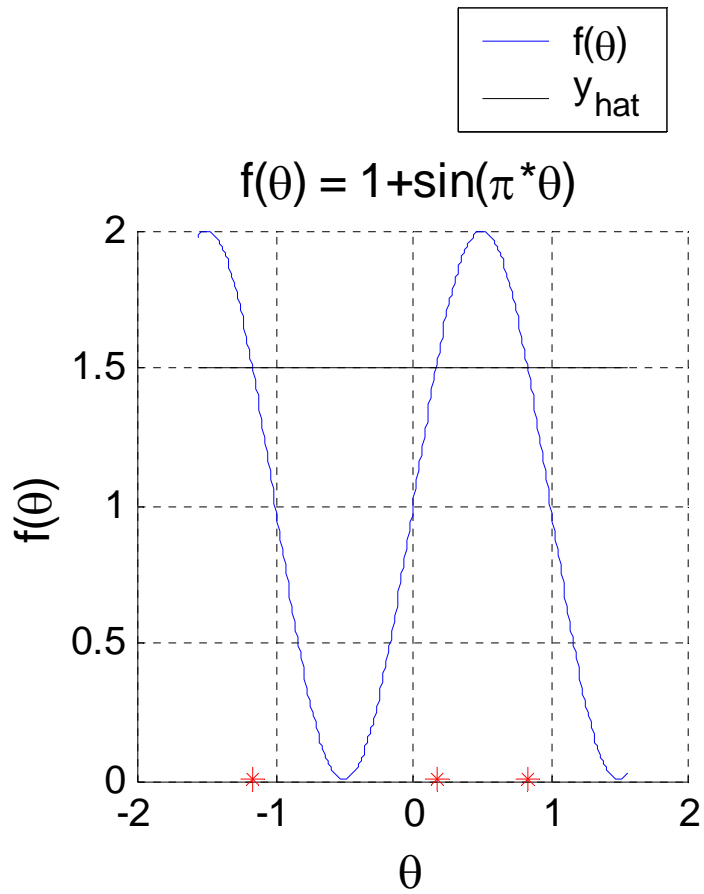

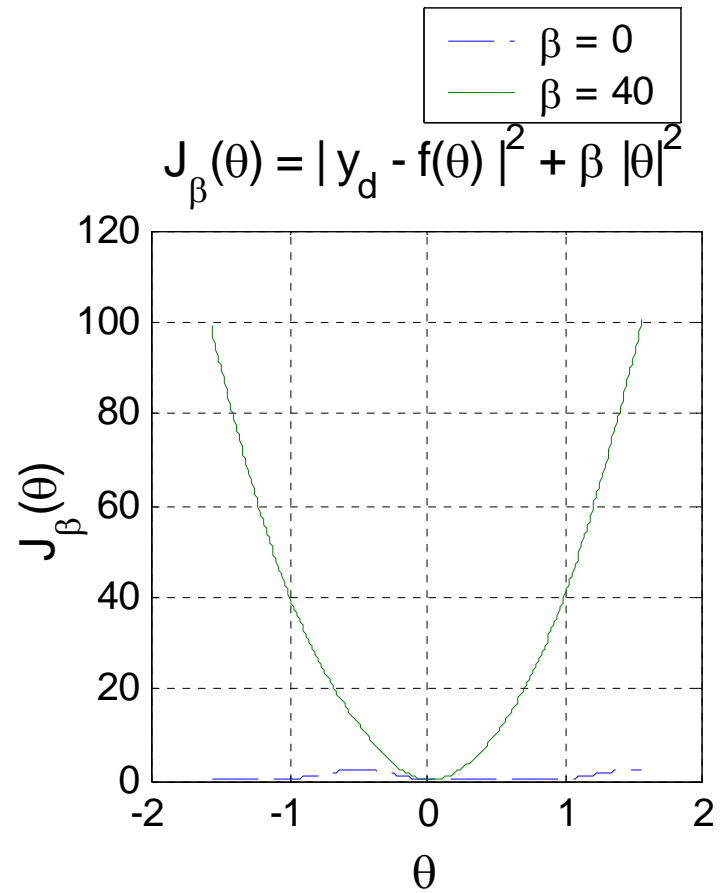
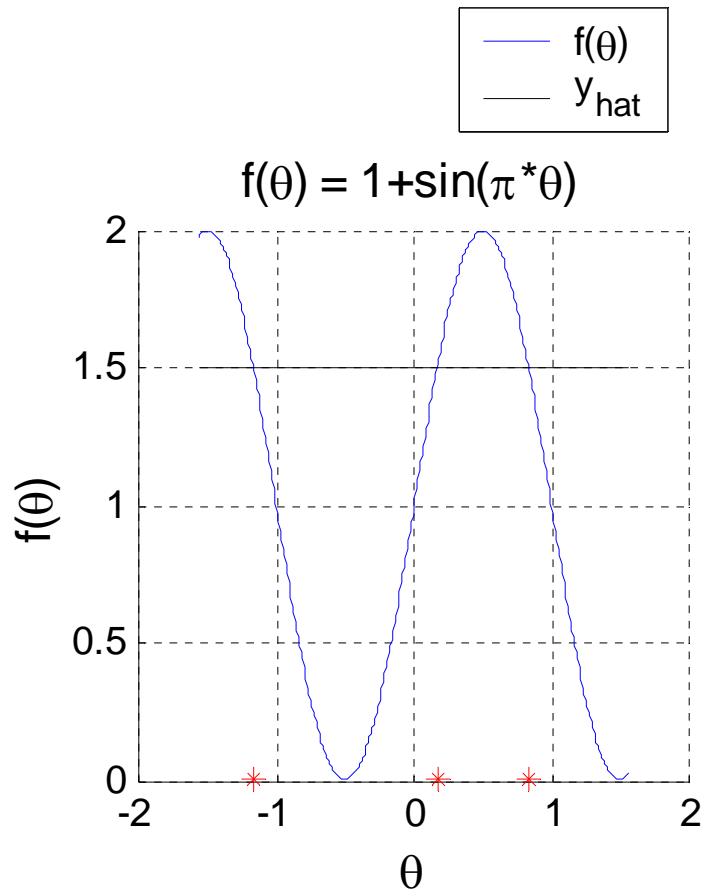

# ***SENSITIVITY***

*How does  $f(t, \theta) = \mathcal{E} z(t, \theta)$  change with respect to  $\theta$  and how does this affect the effort to minimize*

$$J(\theta) = |y_1 - f(\theta)|^2 \quad ??$$

*Recall that  $J'(\theta) = 2(y_1 - f(\theta))(-f'(\theta))$  and Newton*

*$\theta^{k+1} = \theta^k - [J'(\theta^k)]^{-1} J(\theta^k)$  stalls for initial values*

*in  $[\theta_1, \theta_2]$*

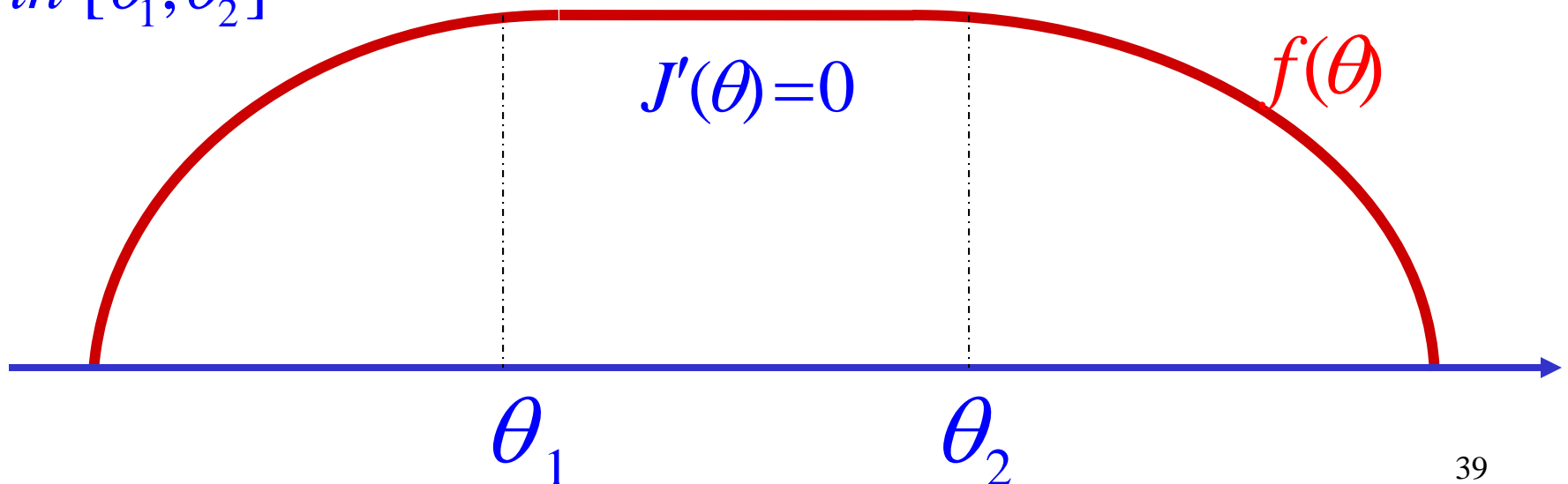

So we are interested in  $\frac{\partial f}{\partial \theta} = e \frac{\partial z}{\partial \theta}$

which is obtained from general sensitivity theory:

Example: For  $\frac{dz}{dt} = g(t, z, \theta)$ , we find  $s(t) \equiv$

$\frac{\partial z(t, \theta^*)}{\partial \theta}$  satisfies  $\frac{ds(t)}{dt} = \left( \frac{\partial g}{\partial z} \right)^* s(t) + \left( \frac{\partial g}{\partial \theta} \right)^*$

where  $\left( \frac{\partial g}{\partial z} \right)^* = \frac{\partial g}{\partial z}(t, z(t, \theta^*), \theta^*)$ ,

$\left( \frac{\partial g}{\partial \theta} \right)^* = \frac{\partial g}{\partial \theta}(t, z(t, \theta^*), \theta^*)$

# *APPROXIMATION/COMPUTATIONAL ISSUES*

*As we have noted, most observations have the form*

$$f(t, \theta) = \mathcal{C} z(t, \theta),$$

*where  $z$  is the solution of an ordinary or partial differential equation. In general, one cannot obtain these solutions in closed form even if  $\theta$  is given.*

*Thus one must turn to **approximations** and **computational solutions**.*

*For example, in the case of  $z$  satisfying an ODE*

$$\frac{dz}{dt} = g(t, z, \theta),$$

*one can apply finite difference techniques to discretize the system, obtaining an algebraic system for  $z_k^N \approx z(t_k)$  given by*

$$z_{k+1}^N = g^N(z_0^N, z_1^N, \dots, z_k^N, \theta).$$

*e.g., Runge – Kutta, predictor – corrector, stiff methods of Gear*

*Thus, one must use*

$$f_k^N(\theta) = e z_k^N(\theta)$$

*in*

$$J^N(\theta) = \sum_{j=1}^n \left| \tilde{y}_j - f_j^N(\theta) \right|^2$$

*which yields solutions  $\hat{\theta}^N$ .*

*Question: What is relationship of  $\hat{\theta}^N$  to  $\hat{\theta}$  ???*

*Convergence, preservation of stability,  
sensitivity, well posedness, etc., of problems,  
solutions ???*

*In the case of partial differential equation systems, one can introduce finite difference or finite element approximations.*

*Example: Finite elements ("linear elements") in dispersion equations – heat, population dispersal, molecular diffusion, etc.*

$$\frac{\partial u(t, x)}{\partial t} = \frac{\partial}{\partial x} \left( \theta(x) \frac{\partial u(t, x)}{\partial x} \right) + F(t, x)$$

*Idea: Look for approximate solutions of the form*

$$u^N(t, x) = \sum_{k=1}^N z_k^N(t) \Psi_k^N(x)$$

*for a given set of basis elements  $\{\Psi_k^N\}_{k=1}^N$ , leading*

*to a system for  $z^N(t) = (z_1^N(t), z_2^N(t), \dots, z_N^N(t))$  to be*

*used in  $f^N(t, \theta) = \mathcal{E}^N z^N(t, \theta)$ .*

# Linear Elements

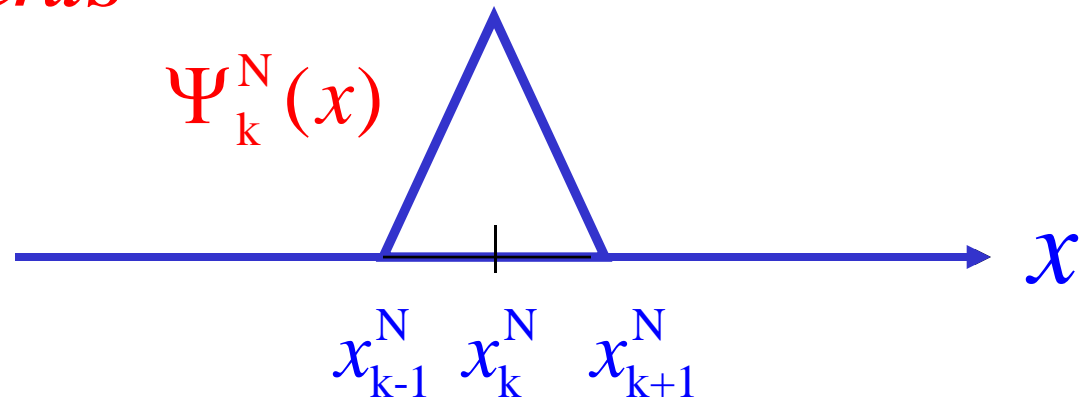

leads to finite dimensional system

$$\frac{dz^N(t)}{dt} = \mathcal{A}^N(\theta) z^N(t) + \mathcal{F}^N(t)$$

where

$$\mathcal{A}^N(\theta) = \left( \int \theta(x) \Psi_i^N(x)' \Psi_j^N(x)' dx \right)$$

Finite elements generally result in large (dimension  $\sim 10,000$ - $20,000$ ) approximating systems!! These can be extremely time consuming in inverse problem calculations. So there is great interest in *model reduction techniques* that will result in substantial reduction in time! To illustrate one such technique (*Proper Orthogonal Decomposition*), we return to the eddy current based NDE example.

## ***SUMMARY REMARKS***

- 1. Two classes of problems (model/design driven-no data, and data driven)**
- 2. In both classes, may need to introduce *variability/uncertainty* (recall PBPK, HIV examples ) even when considering simple case of a single individual**
- 3. If design/model driven efforts are successful (recall eddy current NDE example), most likely will lead to *validation experiments, data*, and necessitate development of *statistical models***
- 4. There are significant issues, challenges, and methodology ( well-posedness, regularization, approximation/computation, model reduction, etc.) that are important to consider in both classes of problems!**